



WARPIING A MIRRIX LOOM FOR TAPESTRY

WWW.MIRRIXLOOMS.COM



1 LOOM SET-UP

This document will show you how to set-up and warp a Mirrix Loom for tapestry weaving with the shedding device. The loom comes fully assembled.

If you do not want to use the shedding device, simply stop at step 22.

If you want to try a simpler method of warping that doesn't allow you to advance your weaving (meaning move it to the back of the loom for more weaving length) check out our [“Easy Warp” instructions](#) and then refer to steps 23 on in this document if you'd like to add on the shedding device.

What you need to warp your loom:

- Loom
- Wooden Clips
- One Warp Coil (also called a spring)
- Warping Bar
- Flat Wrench
- Spring Bar
- Shedding Device
- Shedding Device Handle
- Allen wrench
- Heddles (these can be purchased or made)
- Warp
- A Pair of Scissors
- A Measuring Tape
- Phillips Head Screwdriver (this is not necessary for newer looms with wing-nuts on the clips)

Before you begin weaving on a Mirrix Loom, you need to choose the correct spring (also called a warp coil) to place on the top bar of the loom (or top and bottom if you are using a bottom spring kit).

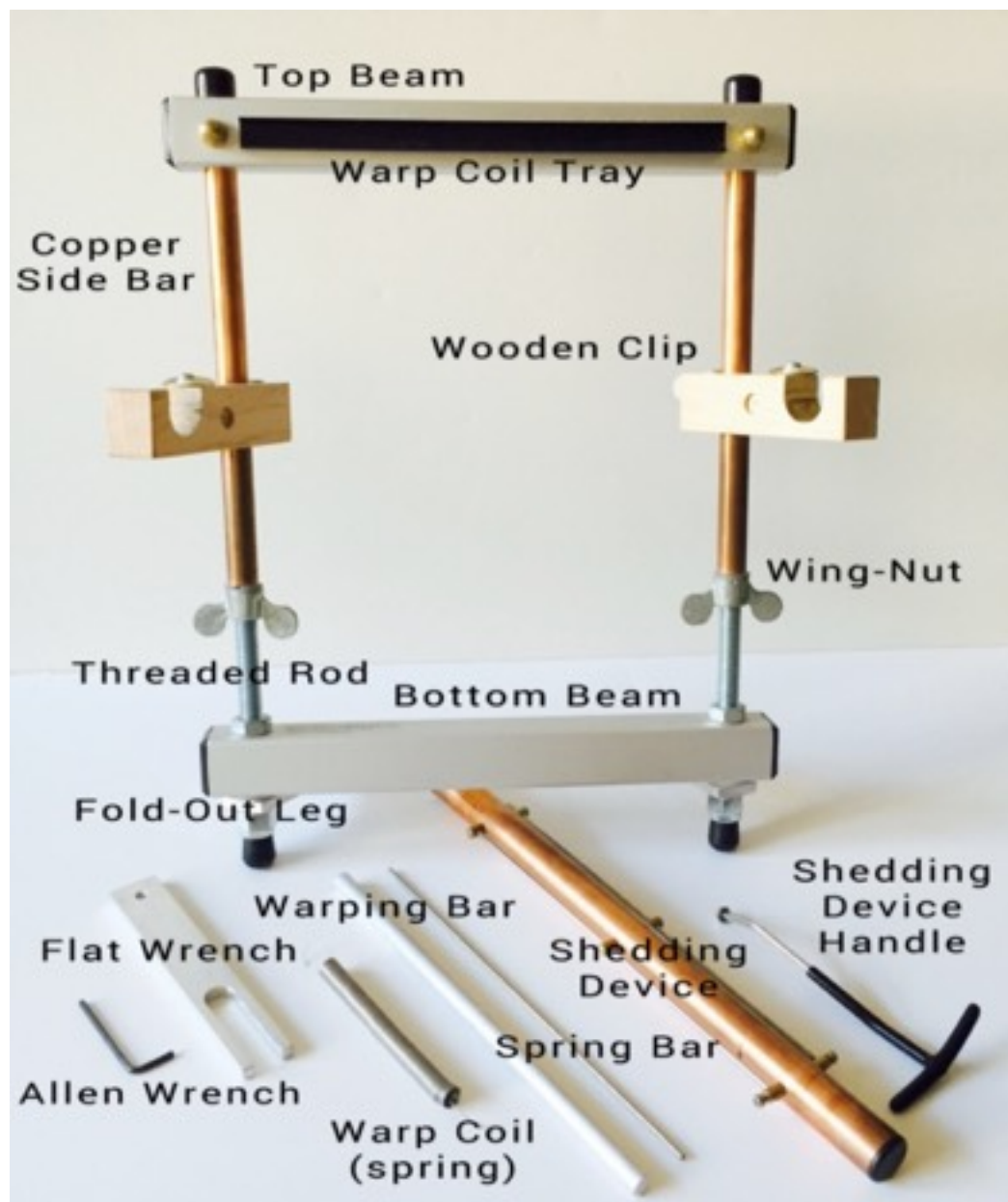

Warp: The thread or yarn that is put on the loom to serve as the base for your weaving. Think of it as your canvas.

Weft: What you weave into the warp. This can be anything from beads to wool to silk to novelty threads . . . whatever your heart desires.

Warp Sett: The space between warp threads

Selvages: The four sides of your piece.

Shed: The space between a lowered and raised set of warps through which you pass your weft or your beads in order to weave them into the warp threads.

Heddle: A heddle attaches your shedding device to your warp threads. Used only when weaving tapestry and bead weaving WITH the shedding device, heddles can be either ordered pre-made or you can make them yourself!

Top Beam: The top beam of every Mirrix Loom is made of aluminum and has rounded edges.

Bottom Beam: The bottom beam of every Mirrix Loom is made of aluminum and has rounded edges. Looms size 28" and larger have double bottom beams for strength.

Copper Side Bar: Each loom has copper side bars.

Threaded Rod: Threaded rod that fits into the copper side bars allows you to adjust the height of your loom and tighten the tension.

Wing-Nut: Wing-nuts are used to adjust the tension on your warp and the height of your loom.

Warp Coil Tray: This tray (which is not on the Mini Mirrix or Sam Loom) holds your springs/warp coils in place at the top of the loom.

Wooden Clip: Wooden clips (not on the Mini Mirrix or Sam Looms) have two functions: To hold your warping bar when warping and to (optionally) hold the shedding device.

Fold-Out Leg: These legs fold-out to allow your loom to stand steadily on any flat surface. The Mini Mirrix does not have legs, the Lani Loom has one and the rest have two.

Shedding Device: This device raises warp threads to make weaving tapestry or beads faster and easier. It comes standard on all looms 16" and larger, but does not have to be used.

Shedding Device Handle: This handle operates the shedding device. It can be replaced by an electric treadle if you are weaving tapestry.

Warp Coil: Warp coils (also called springs) space your warp threads. Choose different warp coils depending on the size or thickness of the beads or warp and weft you are using.

Warping Bar: This bar is what your warp gets tied to when warping. It also helps you to 'advance' your weaving to the back of the loom for more weaving room. This bar is not used for the "easy warp" method of warping.

Allen Wrench: This wrench loosens and tightens the bars on the shedding device.

Flat Wrench: The flat wrench is helpful for tightening and loosening the wing-nuts.



2

WARPING

Warping a Mirrix Loom is straightforward and relatively simple, but it is important to pay attention as you're warping to make sure you aren't making any mistakes, especially when putting on your heddles.

Click [here](#) for some information on **heddle troubleshooting**.

If you are weaving a thin piece relative to the size of your loom, you will want to warp your piece on one side to keep the warping bar balanced. You can learn more about **balancing the warping bar** [here](#).

1.

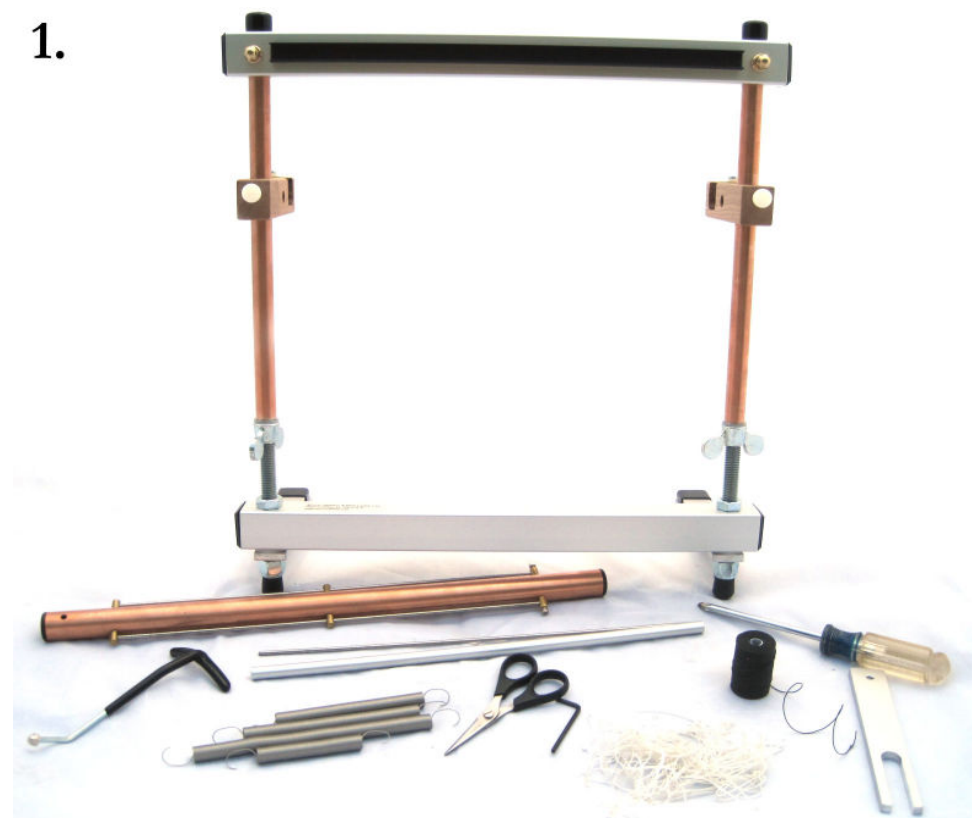

Step One:

Line up the wooden clips 2" to 3" from the bottom of the top beam, facing backwards so the longest part of the clip is behind the loom. You can loosen and tighten the clips to the copper bar using the white plastic screws on the back of the clips.

Newer looms may have clips with plastic screws on the side of the clip. To tighten the clip to the loom, simply move the plastic screw to the back of the clip and tighten.

2.

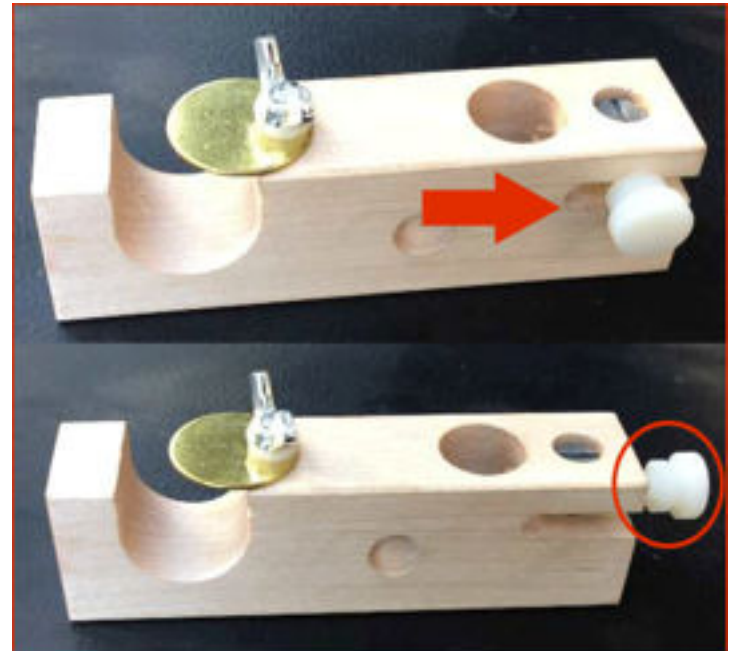
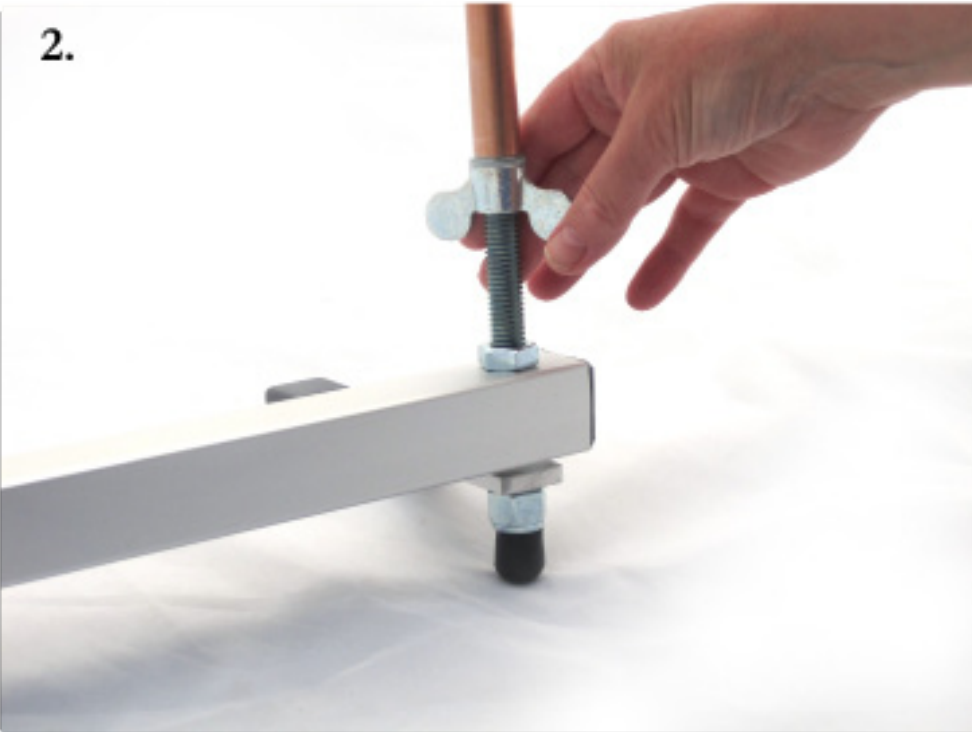

Step Two:

Adjust height of loom to accommodate the length of weaving you plan to make. Do this by rotating the wing nuts (clockwise to shorten the loom and counter clockwise to lengthen the loom.) Make sure you have at least an inch of threaded rod exposed at the bottom in order to be able to adjust your loom for rotating the warp to the back. You can extend your loom to the point where the copper covers at least 4" of the threaded rod when warping on the 8, 12 & 16" looms and 6" on the 22, 28, 32 & 38" looms. Going beyond that point will potentially make your loom unstable. Make sure the loom is even on both sides.

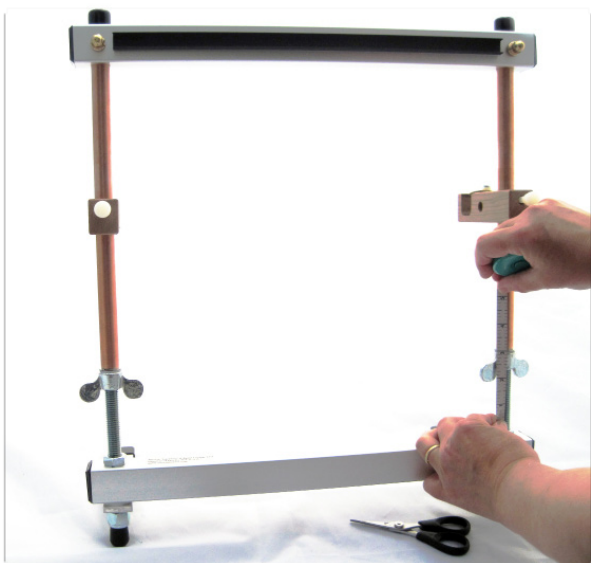

Step Three:

Attach the spring to top of the loom by hooking both ends around the brass nuts, making sure the spring lies flat in the black plastic tray.



Step Four:

Place warping bar inside clips. Clips will be slightly off parallel in order to hold the bar. Push clips toward the bar until it is firmly held in place.

4.

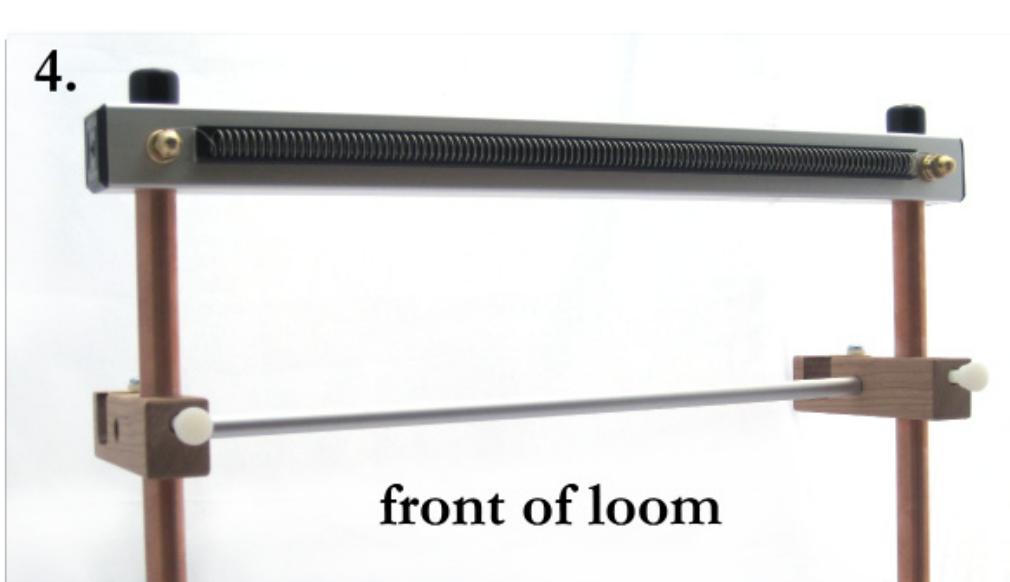

front of loom

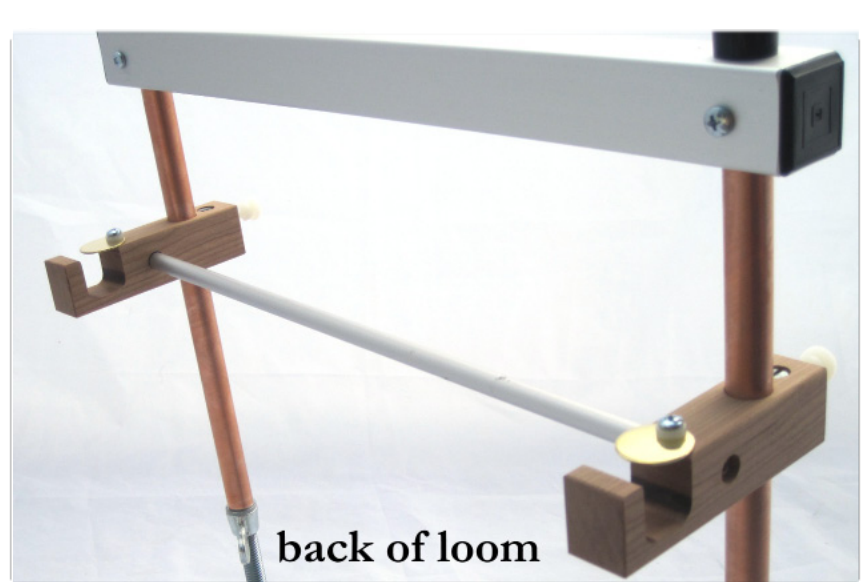

back of loom

Step Five:

Use a square knot to tie your warping thread to the warping bar. Make sure you have enough room to accommodate the width of your piece. While warping the loom, you want to keep an even tension on your thread. You will adjust the loom when you are done warping to put a stronger tension on.

5.

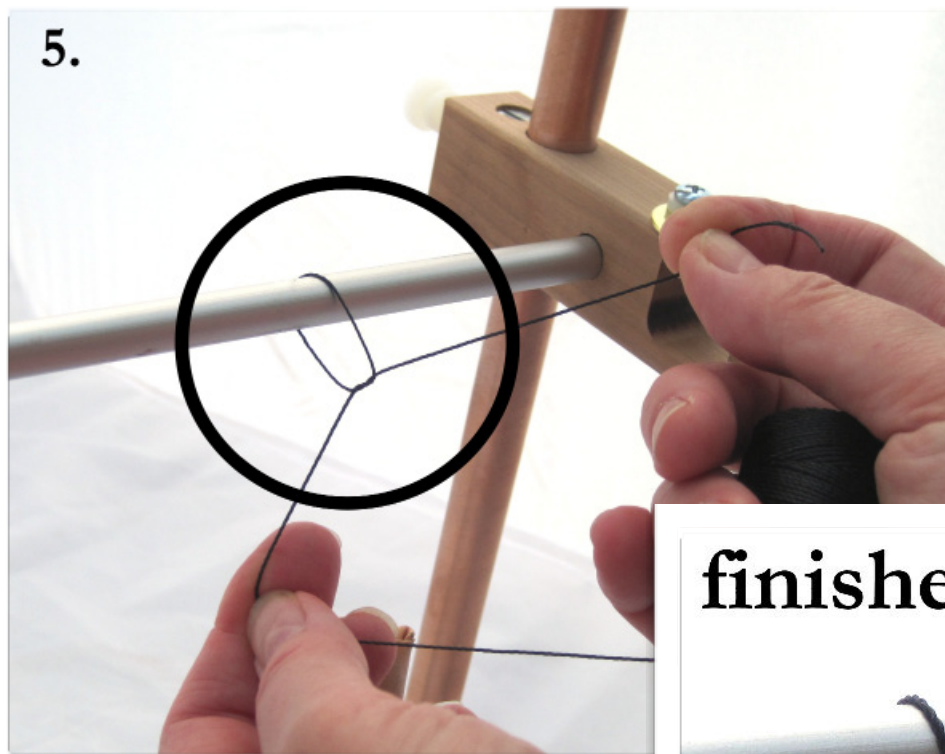

finished knot

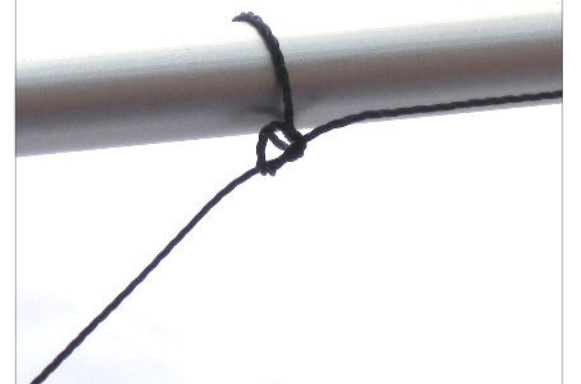

6.

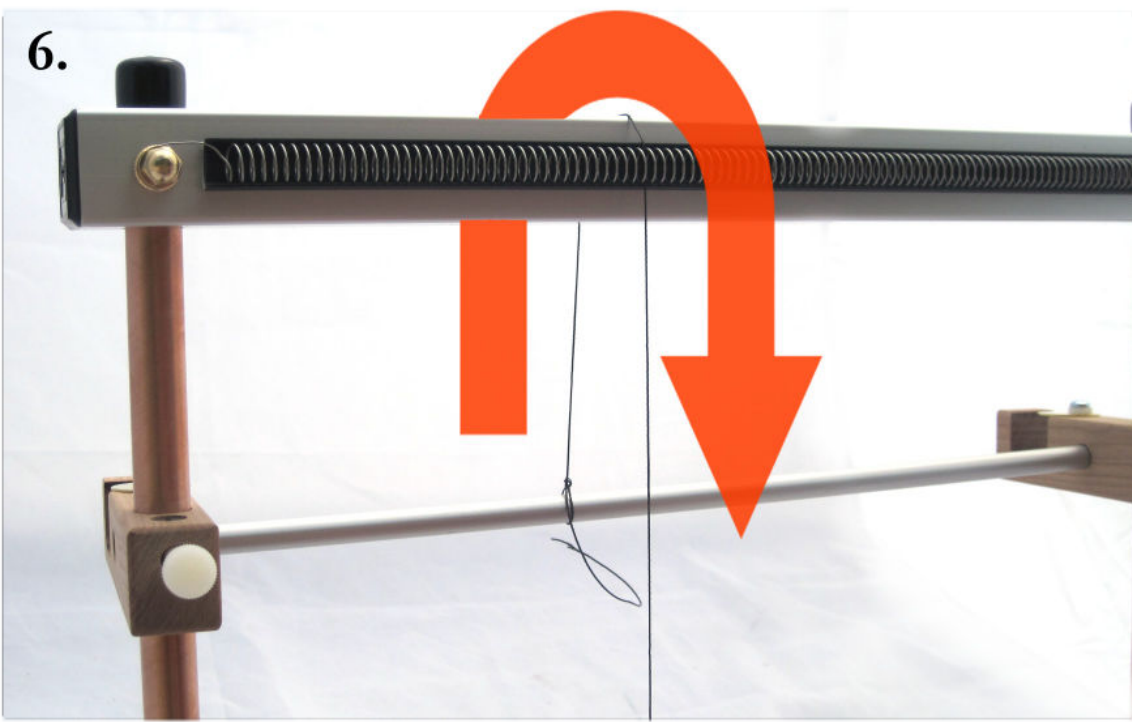

Step Six:

Take the thread up behind the loom and down through one dent (a dent is a space between each coil in the warp coil (spring) in the warp coil (spring)).

7.

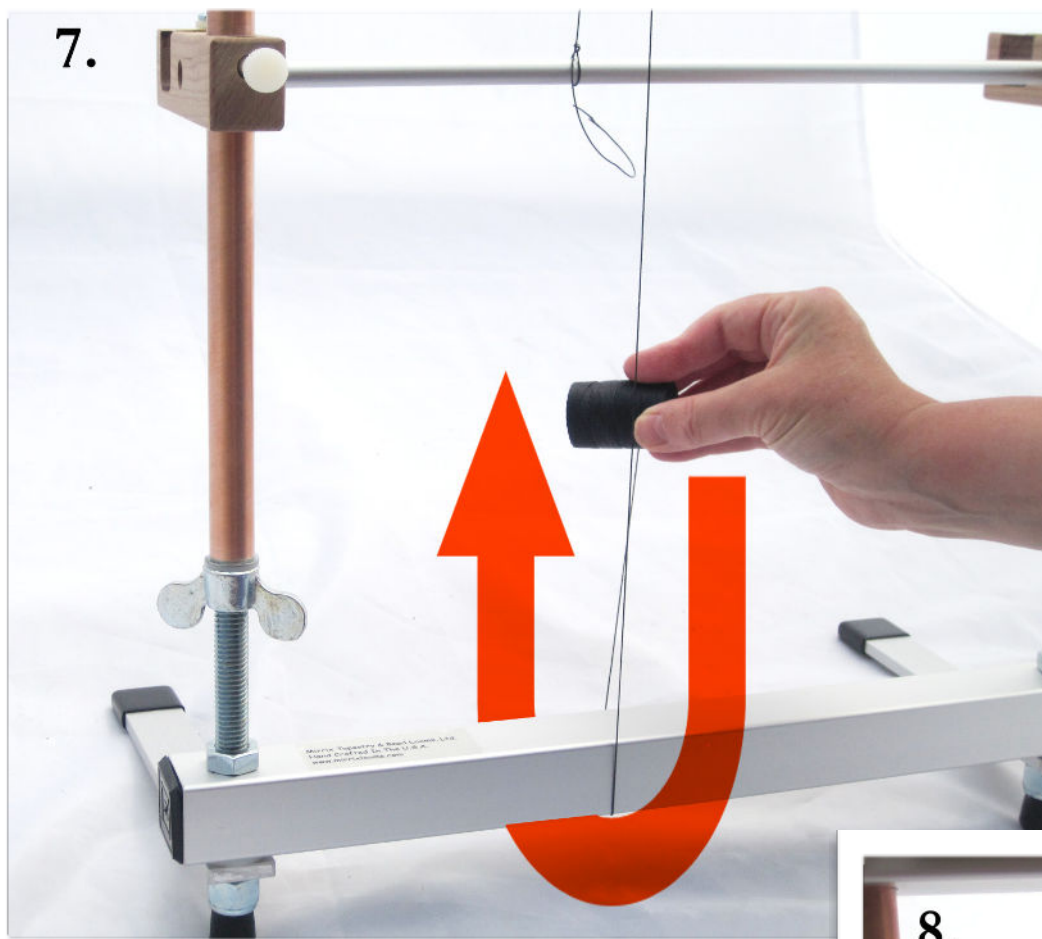

Step Seven:

Take the thread down the front of the loom and around the bottom beam.

Step Eight:

Continue up the back of the loom

8.

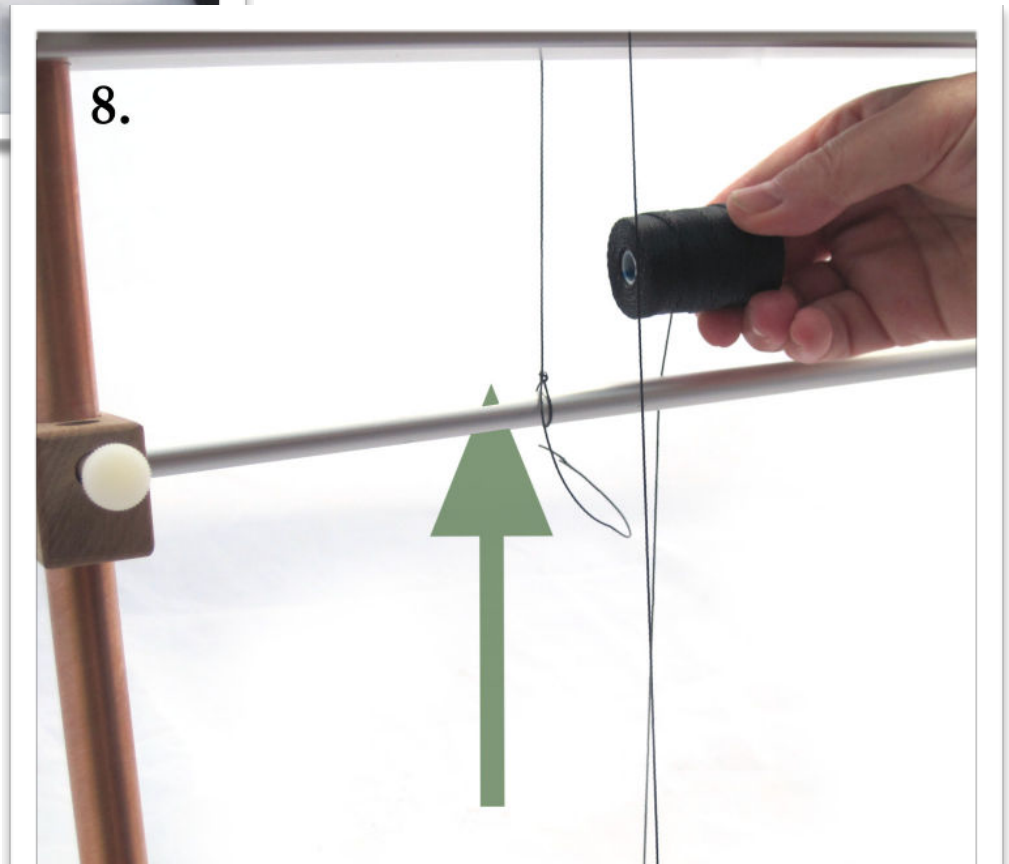

9.

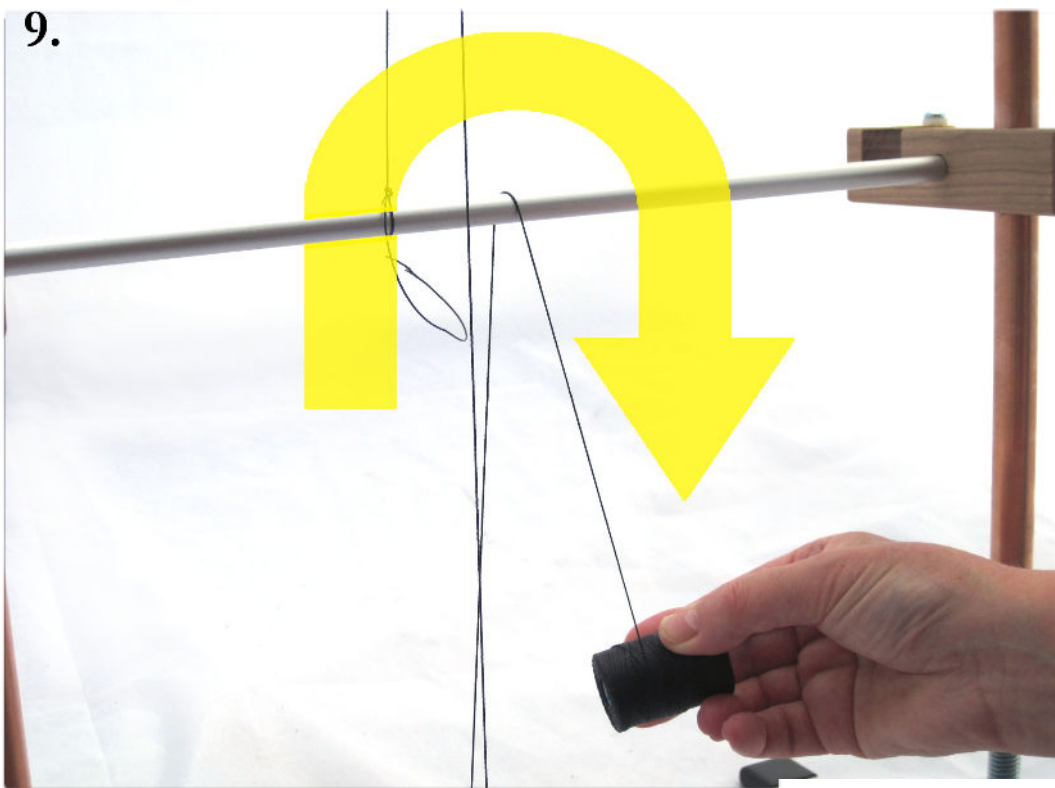

Step Nine:

Do a u-turn around the bar.

Step Ten:

Head back down the back of the loom and go under the bottom beam from the back.

Step Eleven:

Bring thread up the front of the loom to the spring and into the next dent over from the one you just placed your thread in.

10.

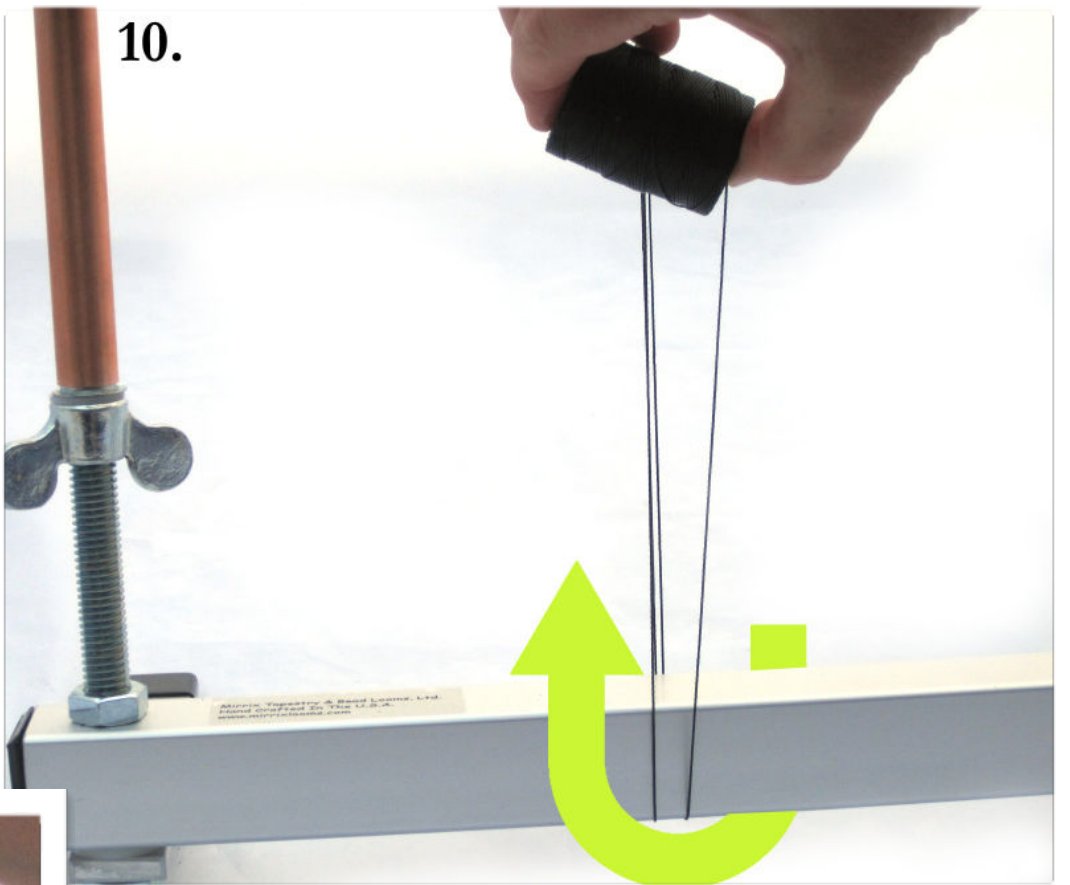

11.

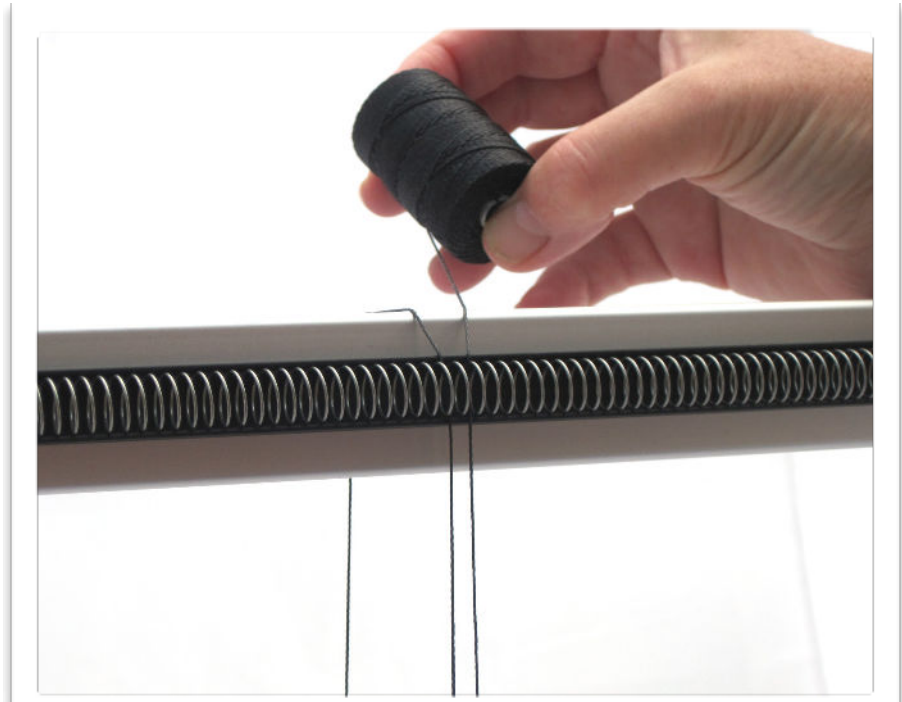
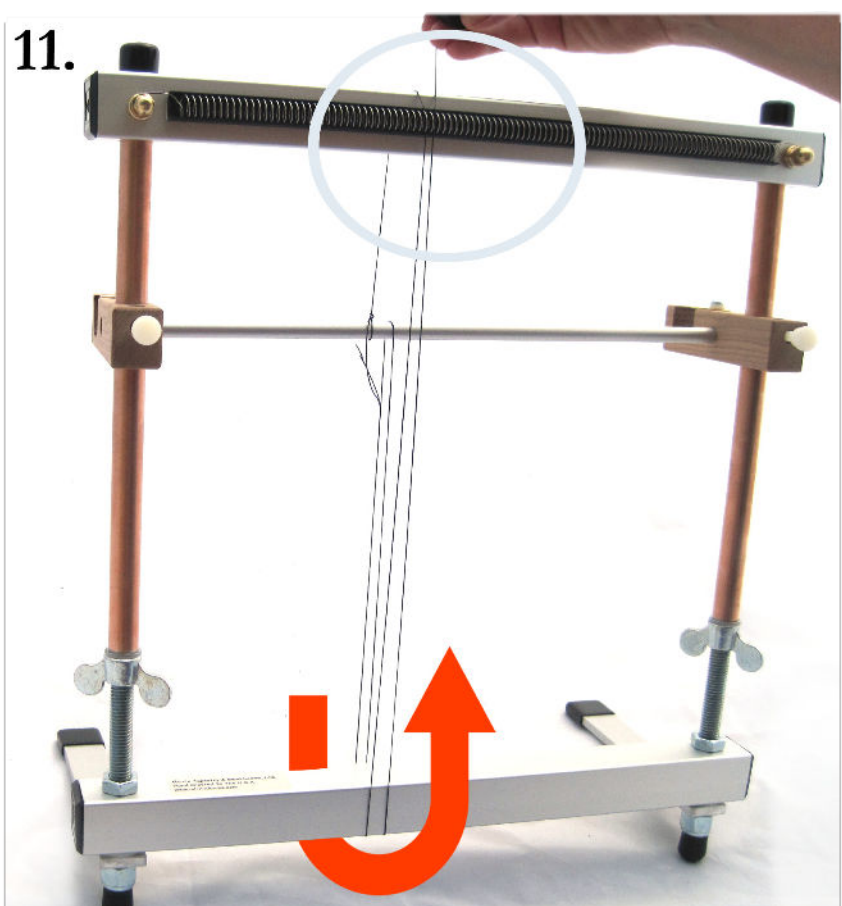

12.

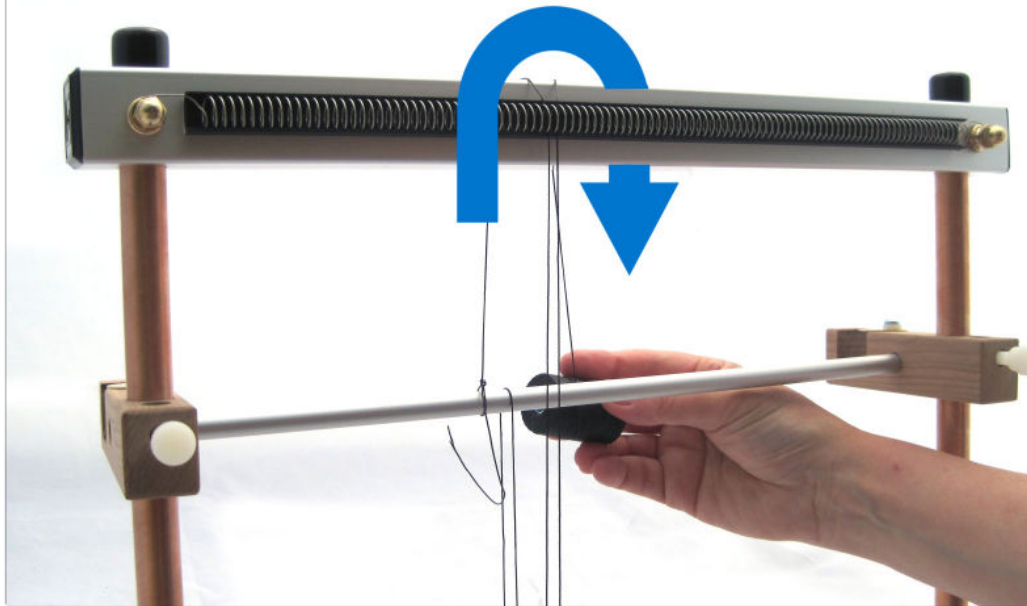

Step Twelve:

Go around the top beam and head down the back of the loom.

13.

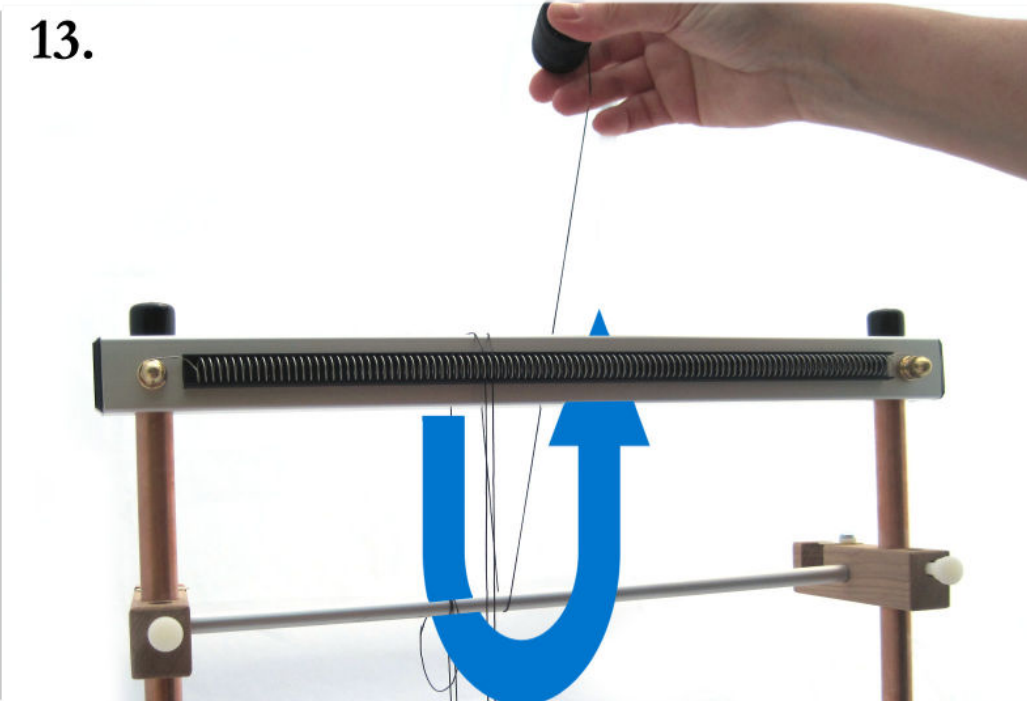

Step Thirteen:

When you reach the warping bar, do another u-turn and head up the back of the loom to the top beam.

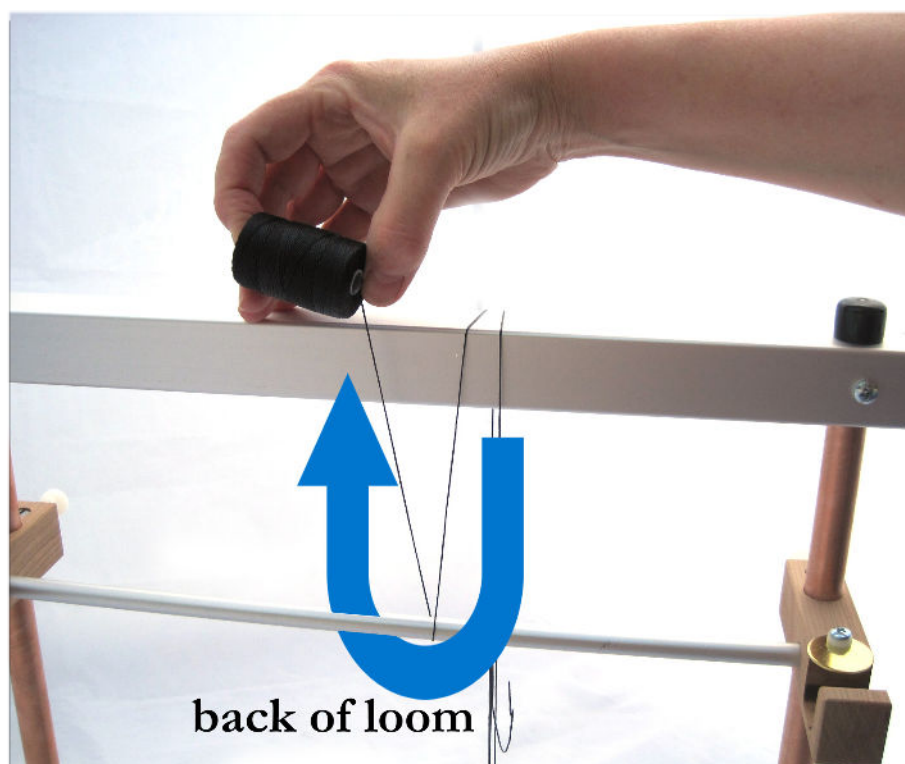

Step Fourteen:

When you reach the spring, place your warp in the next dent over.

14.

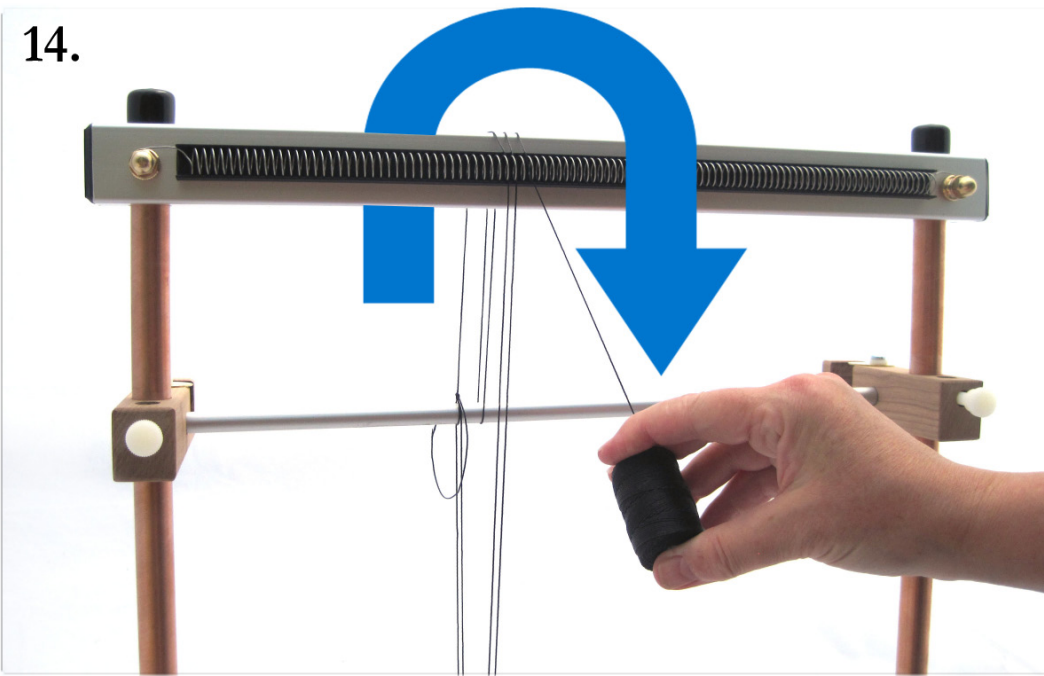

15.

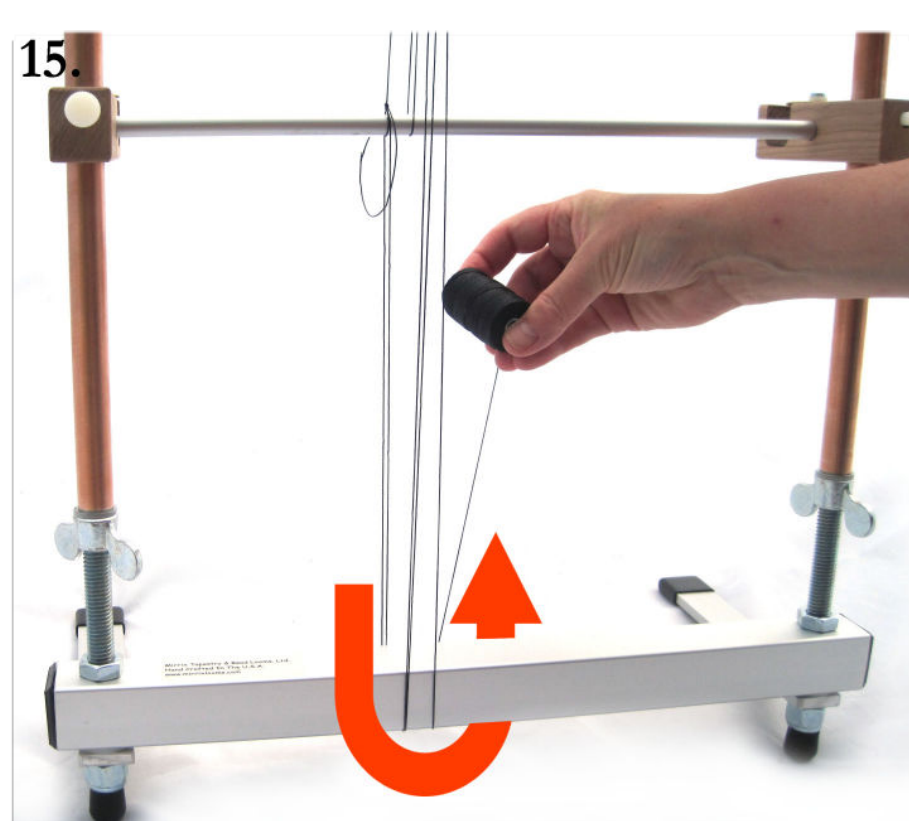

Step Fifteen:

Bring your thread down the front of the loom and around the bottom beam.

Step Sixteen:

Repeat steps 8 to 15 until you have reached the desired number of warps for your piece. Note: If you run out of warp, DO NOT WORRY! Simply tie off to the bar using a square knot and tie on your new thread next to it. Continue as if it was the same thread.

Step Seventeen:

Tie off with a square knot, making sure to keep the appropriate tension on that last string.

17.

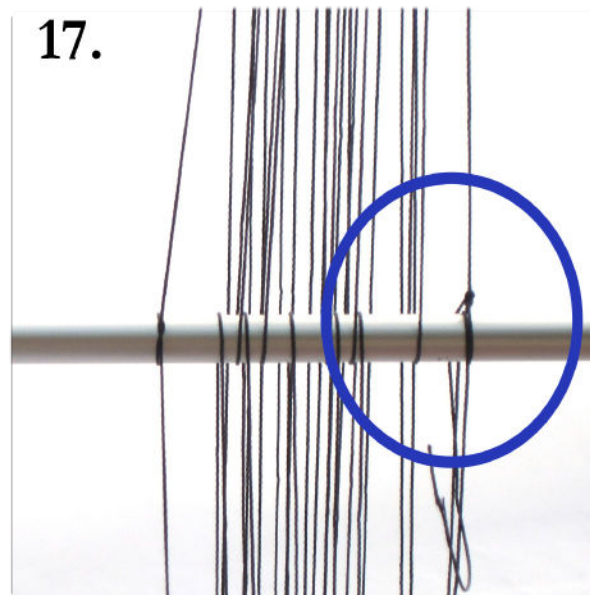

18.



Step Eighteen:

Release tension on loom so you are able to lower the warping bar. (Do this evenly on both sides.) It might only require one clockwise turn of the wing nuts.

Step Nineteen:

Put spring bar in warp coil. (This is to keep the warps securely in the spring.)

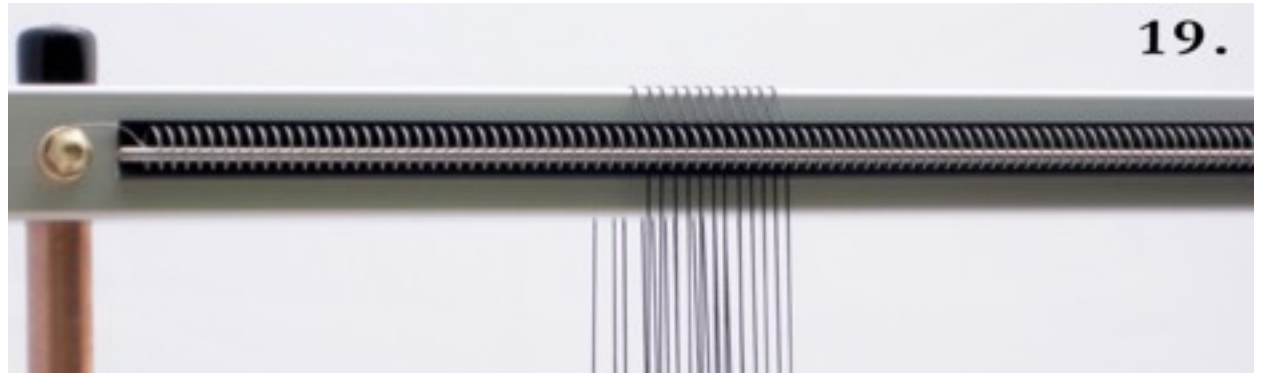

20.

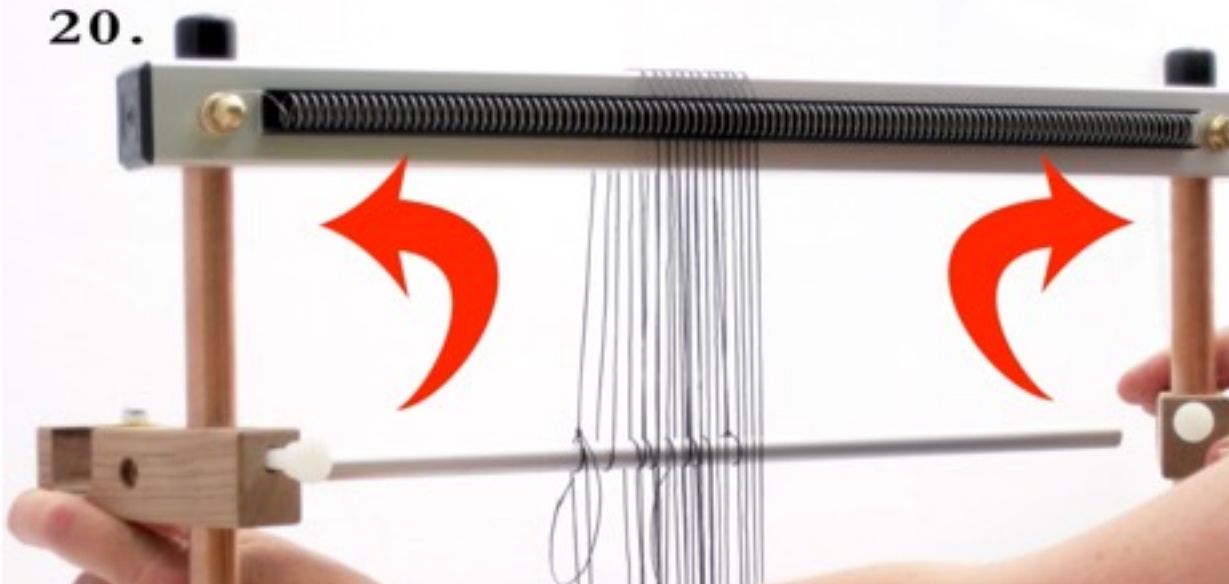

Step Twenty:

Swing clips out to release warping bar.

Step Twenty-One:

Pull down warping bar until it is about two inches above the top of the bottom beam.

21.

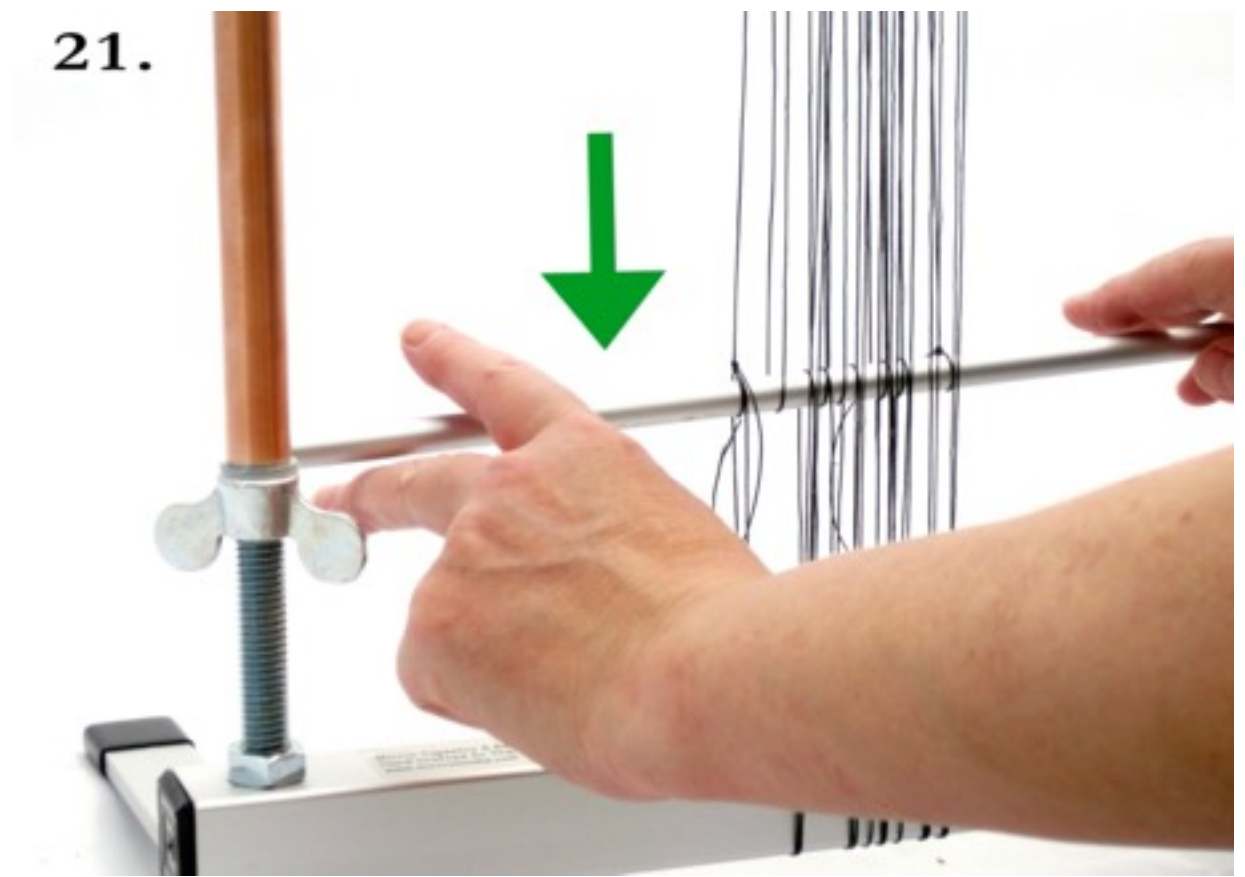

Step Twenty-Two:

Put tension on warp by rotating wing nuts counter clockwise. Put enough tension on the warp so none of the threads are baggy or loose.

Step Twenty-Three:

Swing clips around to front of loom.

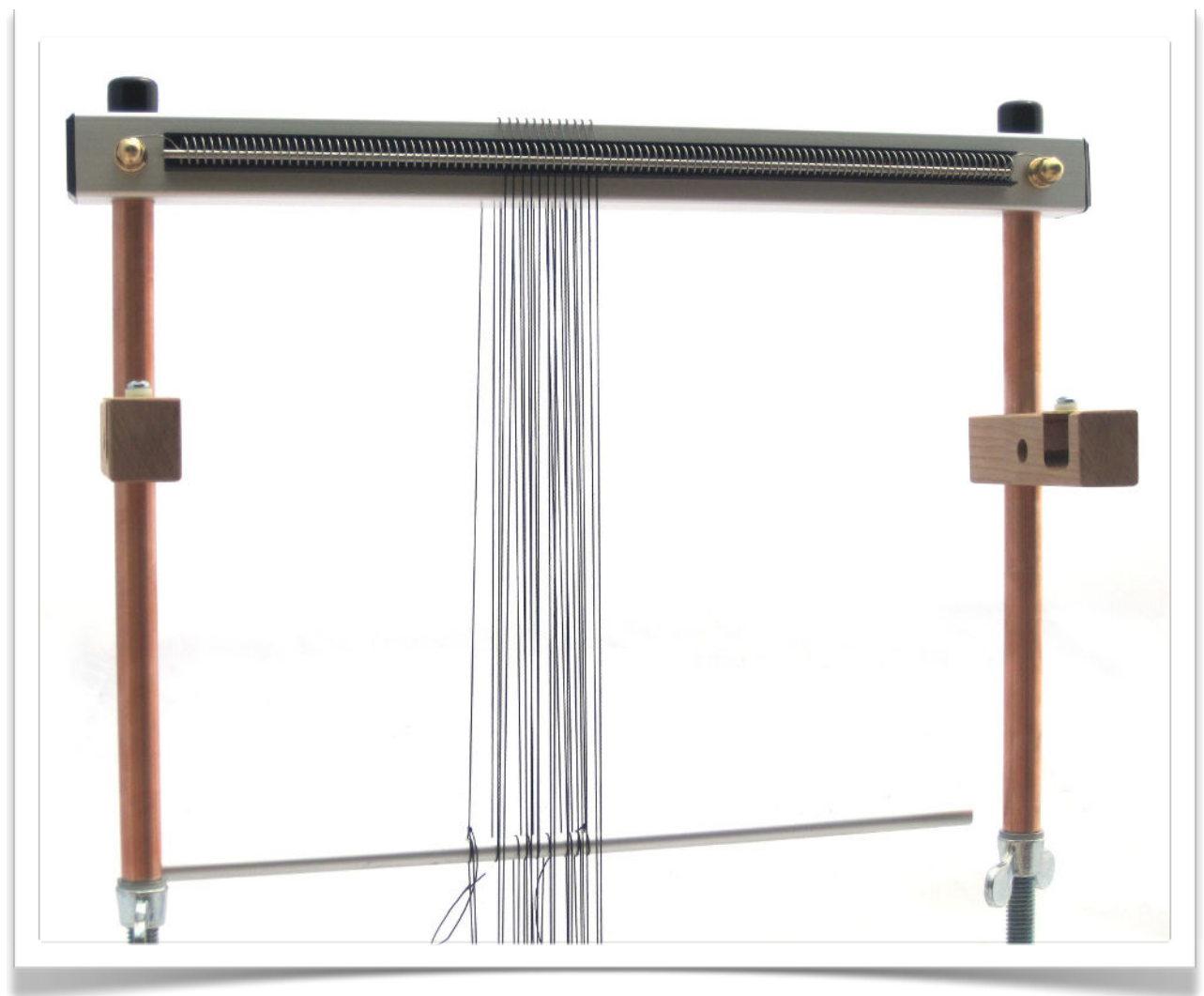

24.

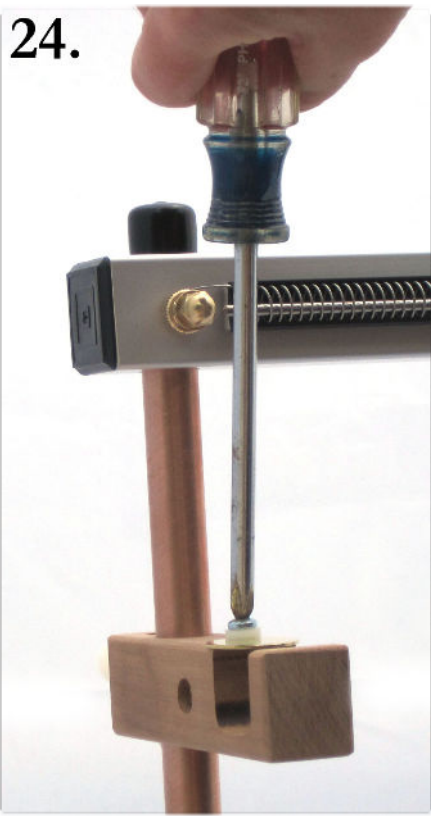

Step Twenty-Four:
Loosen screws in brass plates on clips.

Note:

Newer looms may have wing-nuts on the clips (like the picture below). In this case, you will not need the screwdriver



25.



Step Twenty-Five:

Move brass plates out of the way.

Step Twenty-Six:

Place shedding device into clips. If you are right handed, the hole for the handle should be on the right. If you are left handed, the hole for the handle should be on the left.

26.

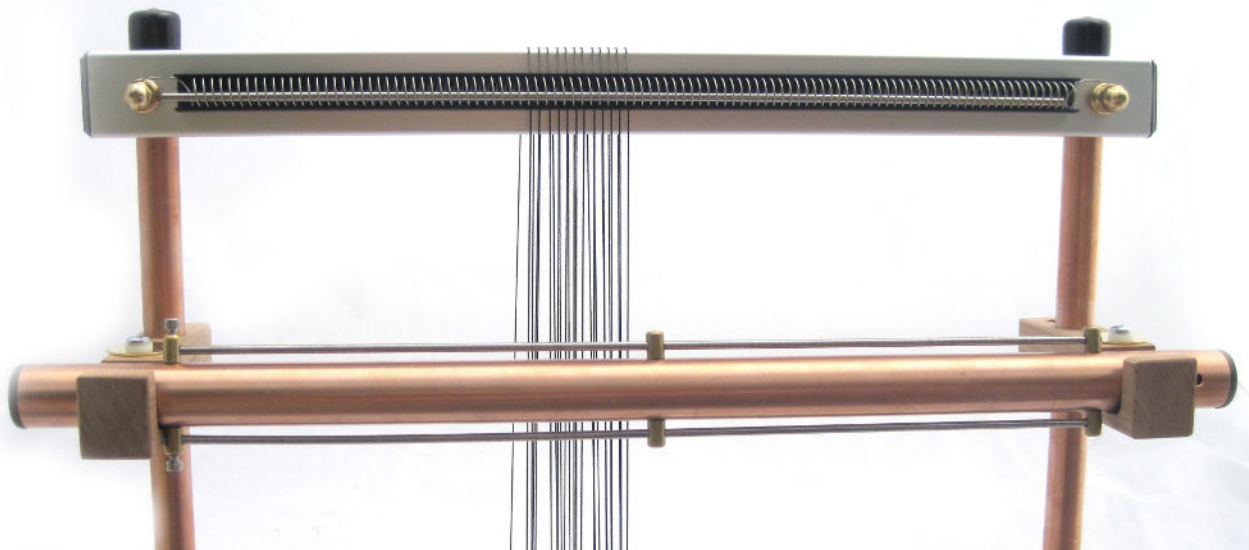

27.

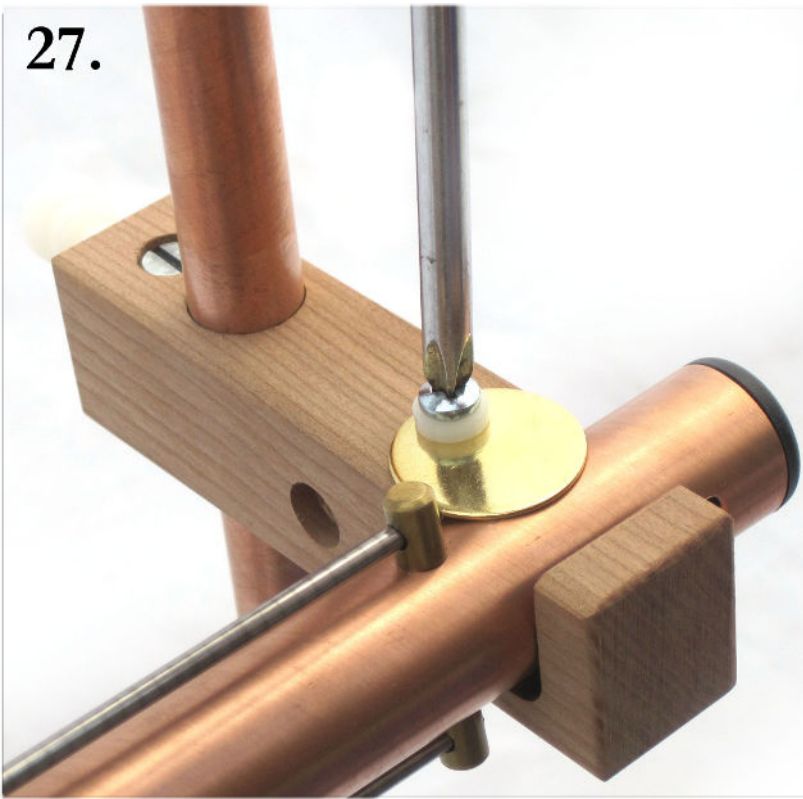

Step Twenty-Seven:
Swing brass plates over
bar on both sides and
tighten.

28.

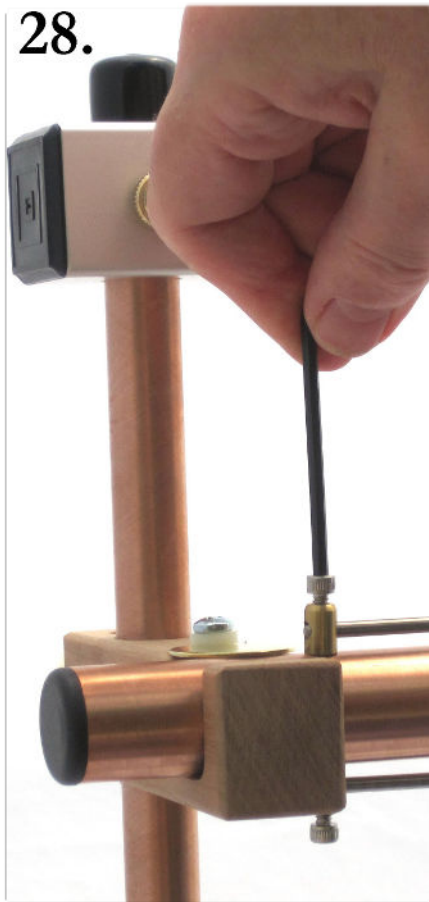

Step Twenty-Eight:

Loosen screw that holds in top heddle bar (the heddle bars are the two bars on the top and bottom of the shedding device that will eventually hold the heddles to create different sheds).

Step Twenty-Nine:

Push the heddle bar partway out and tighten screw slightly.

29.



Step Thirty:

Place heddle around the first warp and loop onto heddle bar. Continue doing this with every other warp. (After this you will put heddles on the other warps and attach those to the other heddle bar allowing each set of warps to be raised separately).

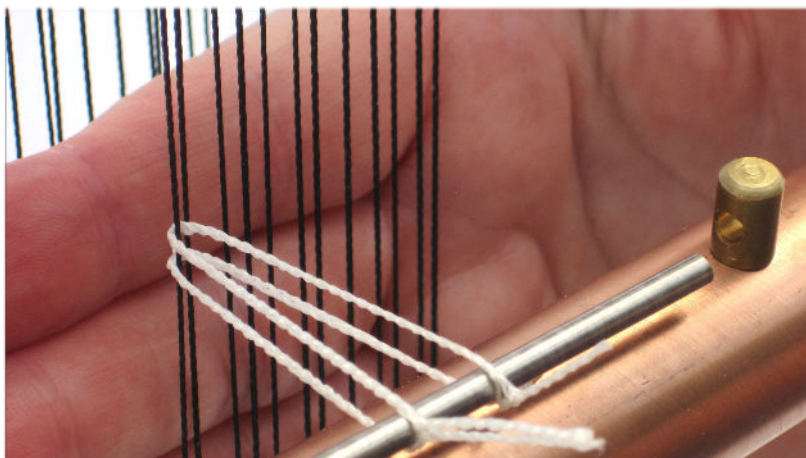
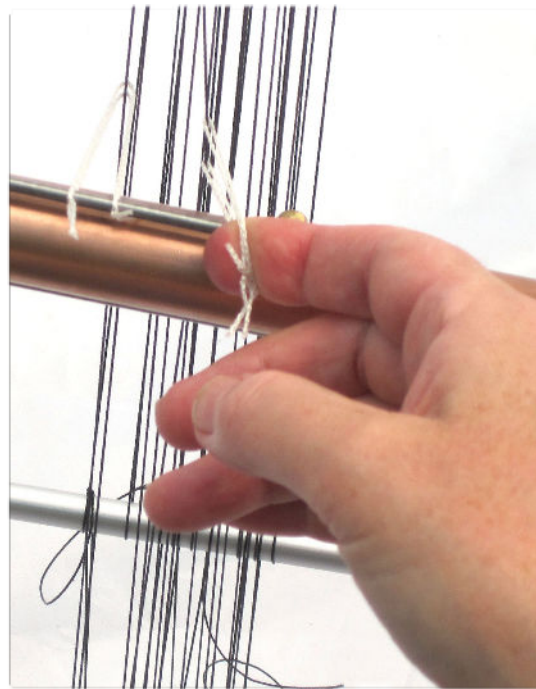
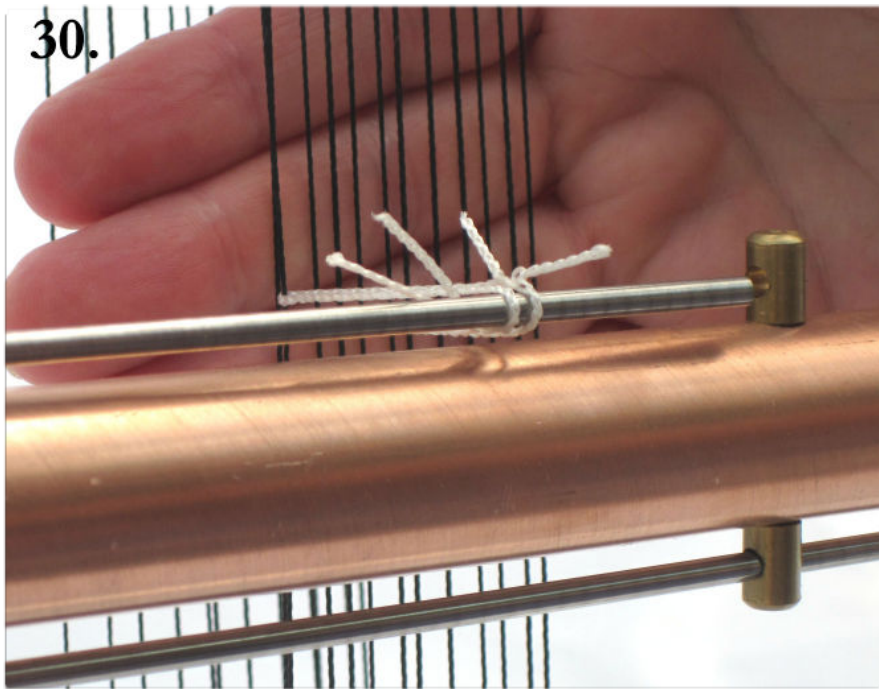

Step Thirty-One

Release screw and reinsert bar.
Tighten screws. Make sure bar is
flush with side of brass holder.

32.

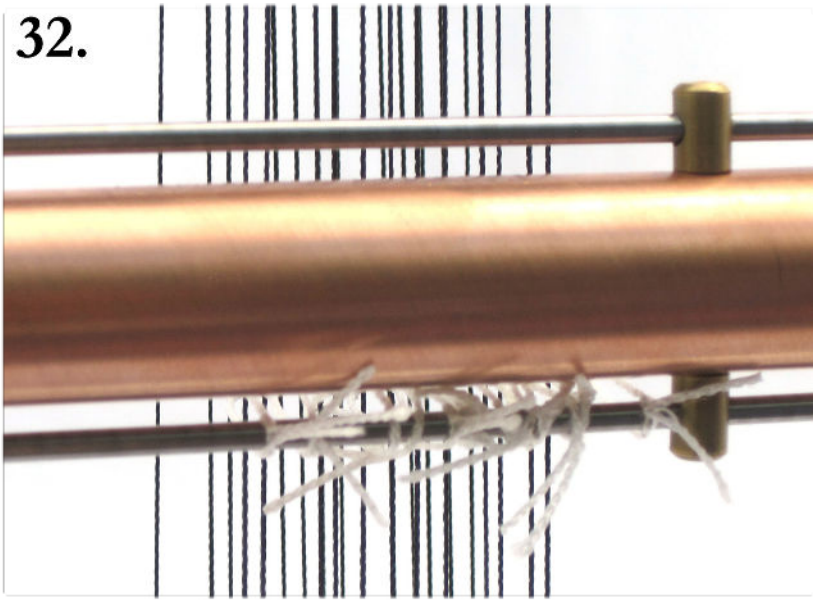

Step Thirty-Two:

Rotate shedding device toward the loom so that the empty spring bar is now on top.

33.

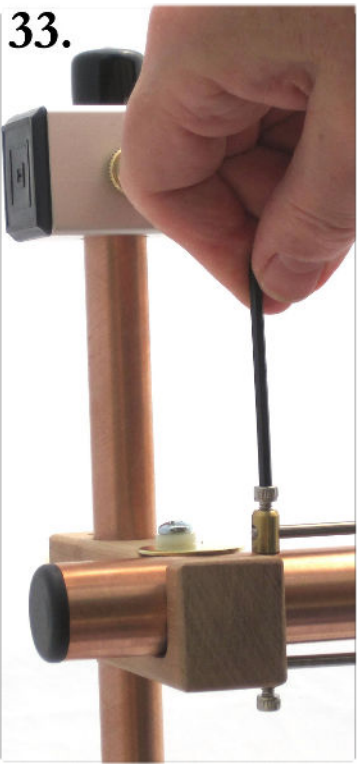

Step Thirty-Three:

Loosen other heddle bar (which should now be on the top of the shedding device).

Step Thirty-Four

Remove heddle bar partway and tighten slightly.

34.

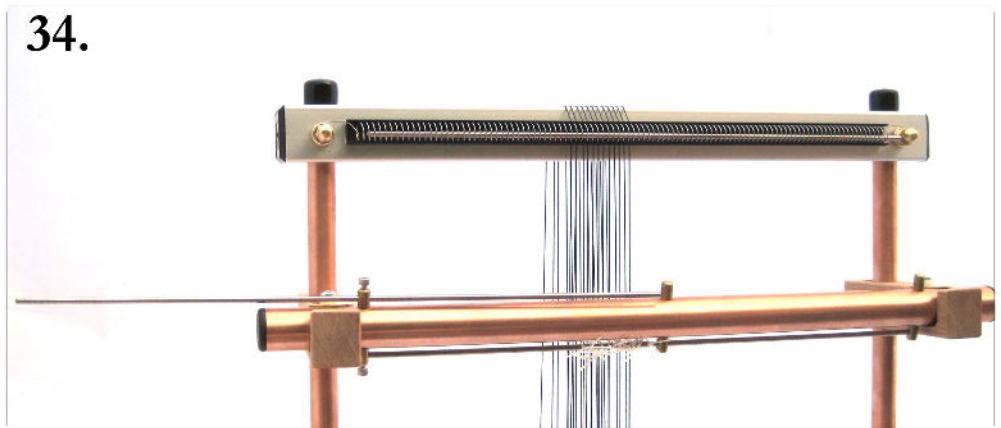

35.

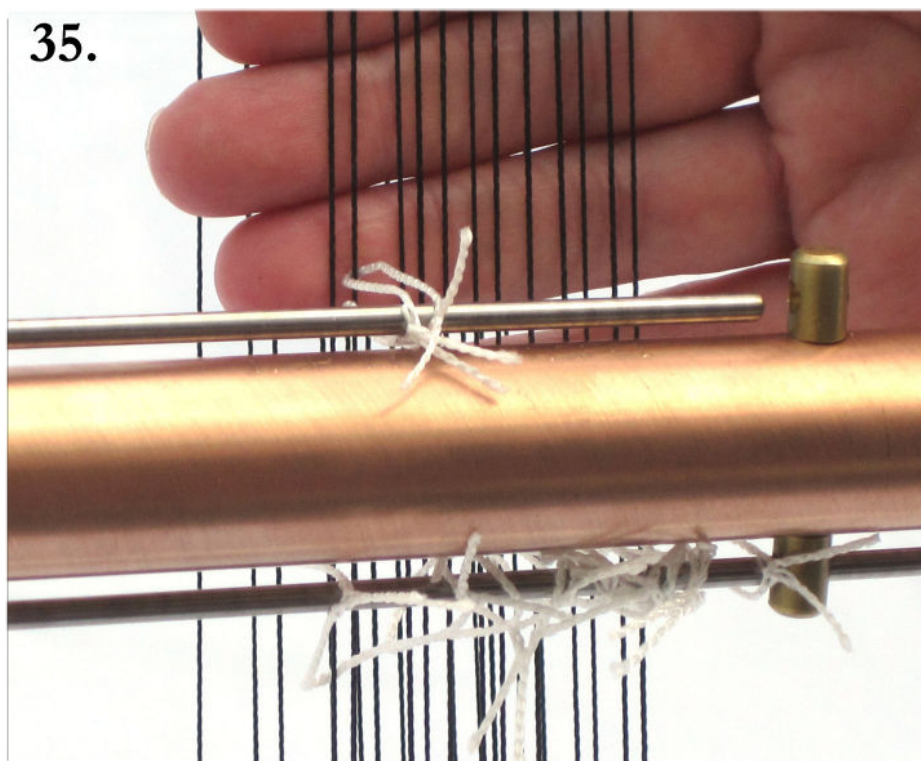

Step Thirty-Five

Insert heddle around first warp that does not already have a heddle on it. Continue doing this with every other warp, making sure there is only one heddle on each warp.



Step Thirty-Six:

Put bar back and tighten screw.

Step Thirty-Seven:

Remove acorn nut from handle.

37.



Step Thirty-Eight:

Stick handle in shedding device and put nut back on.

38.

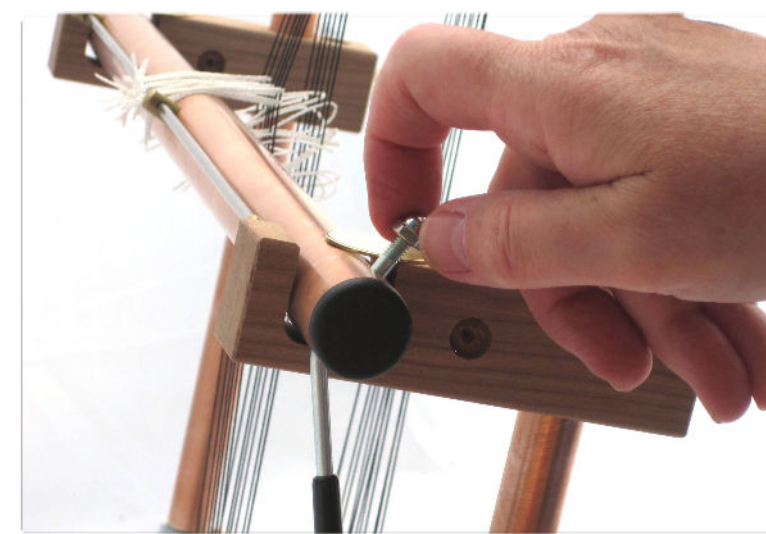

39.

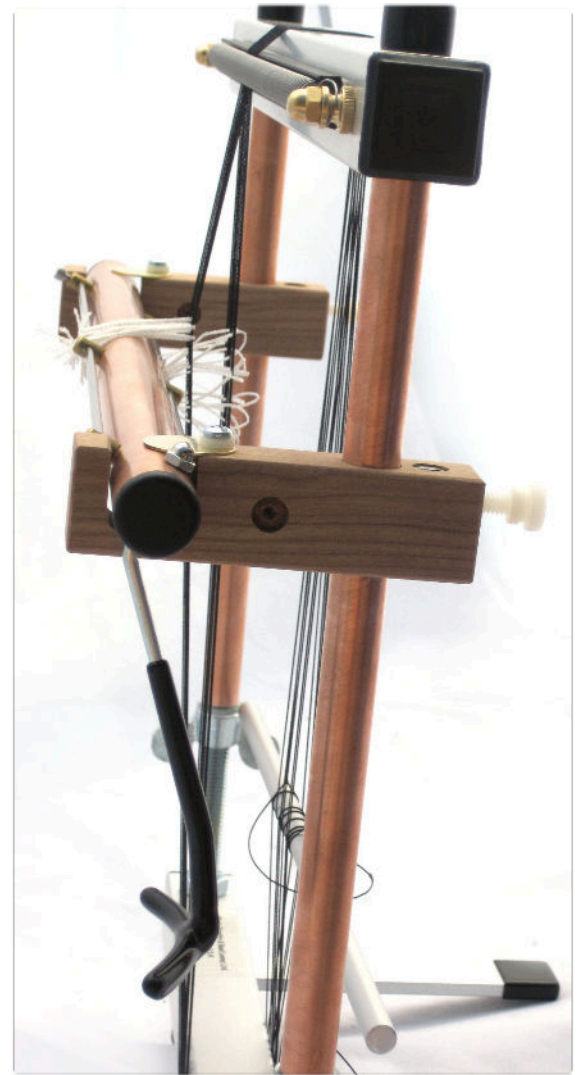
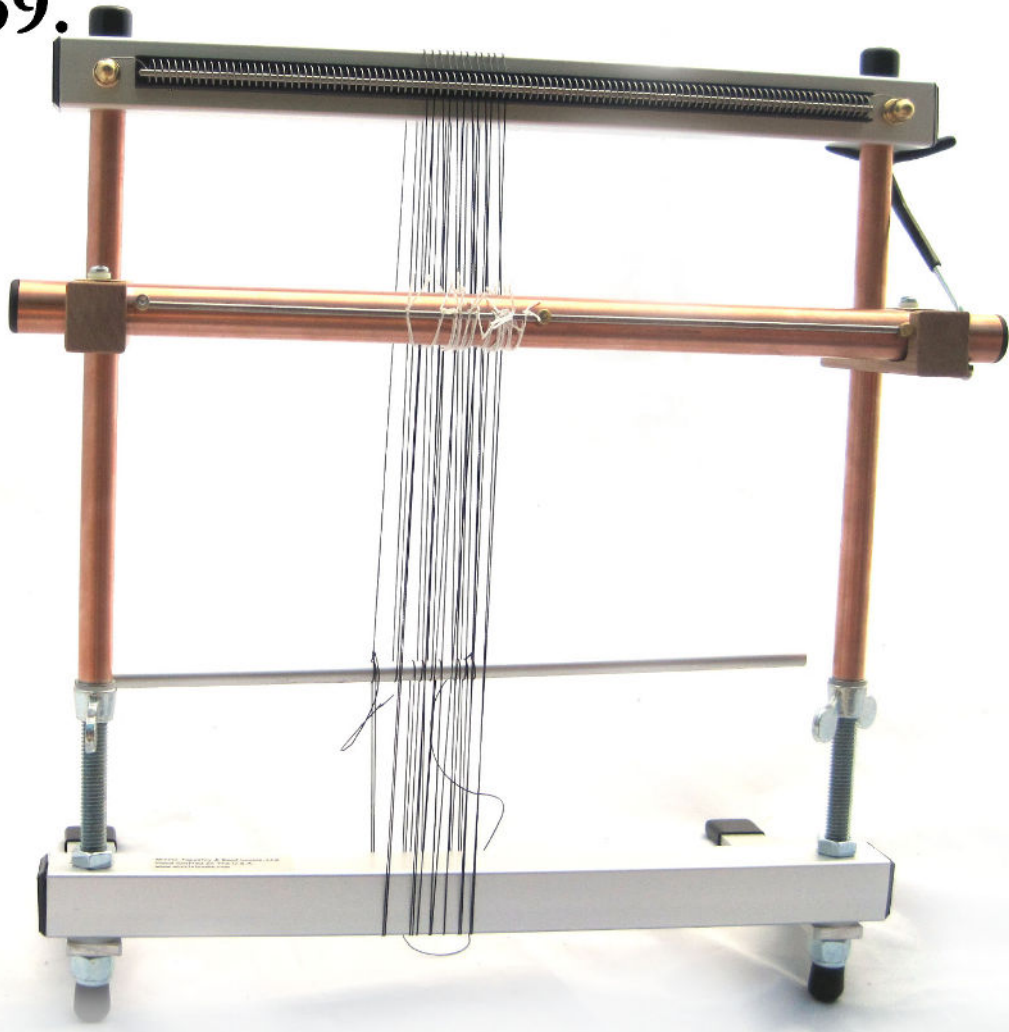

Step Thirty-Nine:
Begin weaving!